



INSTALLATION INSTRUCTIONS

501-1101-B

CHEVROLET 2016+ 6th Generation

Camaro

V6-3.6L

FILTER CF-7322

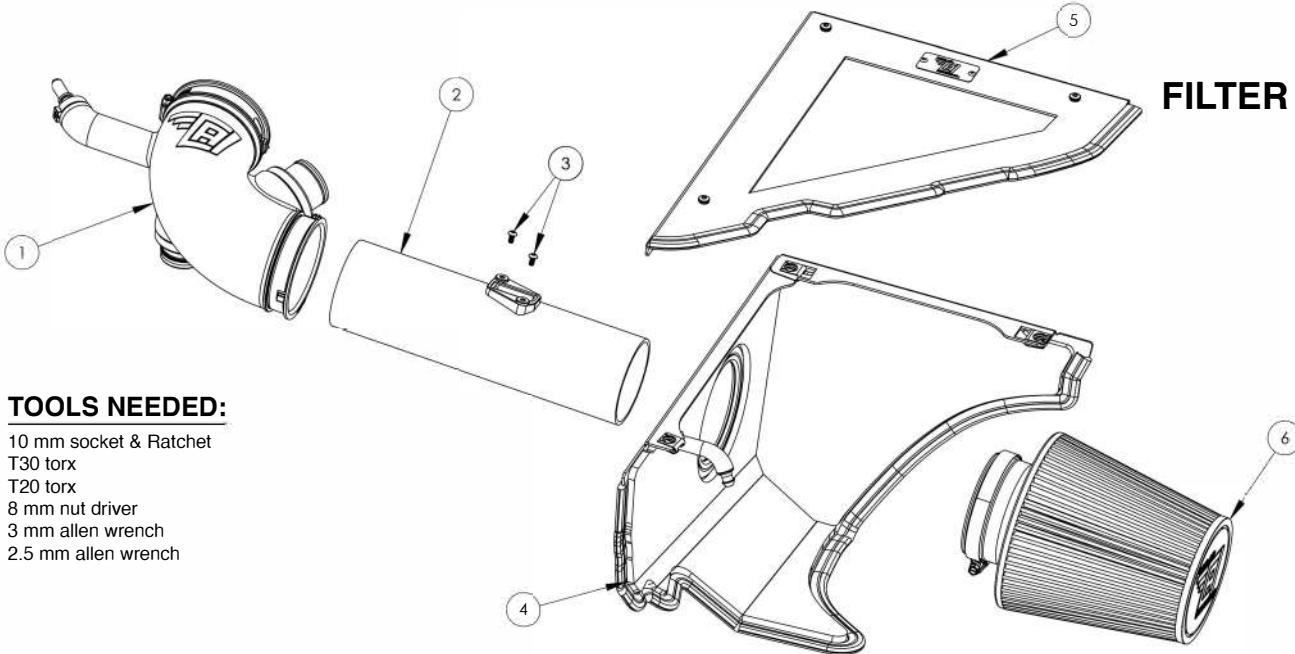

TOOLS NEEDED:

10 mm socket & Ratchet
T30 torx
T20 torx
8 mm nut driver
3 mm allen wrench
2.5 mm allen wrench

ITEM NO.	PART NUMBER	DESCRIPTION	QTY.
1	ITR-0003	INLET/DUCT	1
2	ITA-0024-60	MAF/TUBE	1
3	FTN-0001-BCM	M4-0.7 x 8mm S.S. BUTON HEAD CAP SCREW	2
4	BOX-0025-70B	AIR INDUCTION HOUSING	1
5	LID-0023-70B	COVER-I/H	1
6	CF-7322	FILTER ELEMENT-A/CL	1

If you need any assistance, please visit our website www.coldairinductions.com to view the install video or call 1-810-392-9999 to speak with a customer service representative.

NOTE: FAILURE TO FOLLOW INSTALLATION INSTRUCTIONS AND NOT USING THE PROVIDED HARDWARE MAY DAMAGE THE AIR INDUCTION SYSTEM, THROTTLE BODY AND ENGINE.

REMOVAL OF OEM SYSTEM



1. Turn off the ignition. Allow engine bay to cool before installation.



2. Open the battery access panel in the trunk, on passenger side. Disconnect the negative battery cable with the 10mm socket and ratchet.



3. Remove oil fill cap.

Next page



4. Remove screws on engine cover lid with T30 torx driver.



5. Remove engine cover.



6. Loosen hose clamps with 8 mm nut driver.



7. Disconnect PCV fitting.



8. Disconnect PCV hose.



9. Disconnect sound enhancer tube.



10. Remove the INLET/DUCT from the throttle body.



11. Remove wire clip from air induction housing.



12. Disconnect MAF Sensor.



13. Gently remove the production air induction housing.



14. Reinstall any of the 3 OEM grommets that may have stayed attached to factory air induction housing assembly.

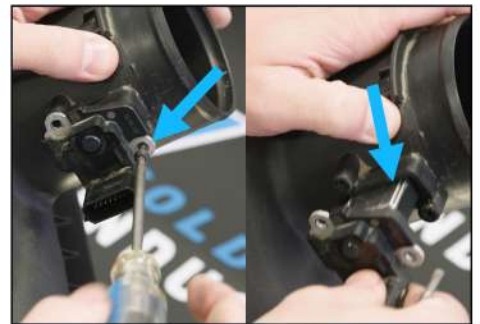

15. Remove the 2 Torx Screws holding the MAF Sensor in place with the T20 torx driver. Remove the MAF sensor and set aside.

INSTALLATION OF NEW CAI SYSTEM

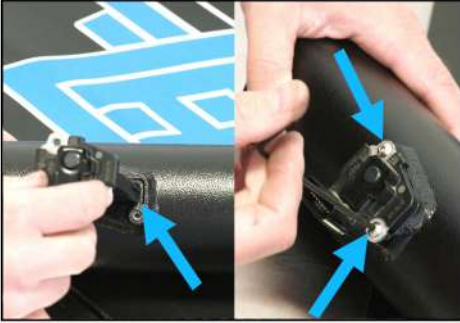

16. Remove button head cap screws from MAF/TUBE. Install MAF Sensor and then re-install provided screws using a 2.5MM Allen wrench.



17. Install performance air induction housing.



18. Insert the filter element into the performance air induction housing.



19. Install MAF/TUBE into filter element, making sure the dot is facing the element.

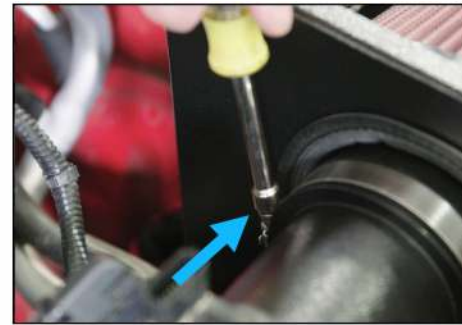

20. Using 8 mm nut driver tighten element onto MAF/TUBE.



21. Connect the performance INLET/DUCT to the performance MAF/TUBE and throttle body.



22. Reconnect PCV tube.



23. Reconnect sound enhancer tube.



24. Reconnect PCV tube, make sure nipple is over top of flange.



25. Tighten all clamps.

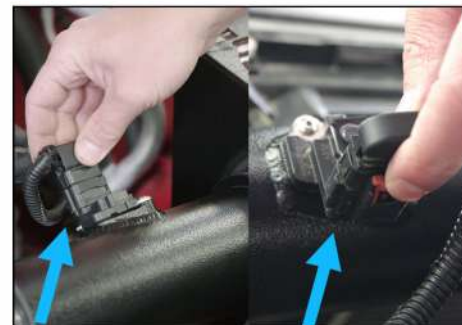

26. Reconnect MAF sensor.



27. Prepare housing cover for installation, by removing protective film over glass.



28. Attach the housing cover over the performance air induction housing, using a 3mm alien wrench, gently push and turn the fasteners a quarter turn.



29. Reinstall the engine cover.



30. Replace oil fill cap.



31. Reinstall screw on the engine cover with the T30 torx driver.



32. Slowly lower your hood and check for clearance.



33. Reattach the negative cable on the battery and reinstall the access panel.

34. Time for a test drive.

*****IMPORTANT*****

Warranty Registration Instructions

***This product comes with a Limited Lifetime Warranty against material defects and product craftsmanship. The intake kit must be registered online for your warranty to be activated. To register your product go to:

www.coldairinductions.com/contact-us/register



NOTE: NOT LEGAL FOR SALE OR USE IN STATE OF CALIFORNIA



Cold Air Inductions Inc. 717 Burnell Rd. Memphis, MI 48041
Phone: 810-392-9999 Monday-Friday 8:00 am to 4:30 pm EST
Web: coldairinductions.com Email: support@coldairinductions.com