



INSTALLATION INSTRUCTIONS

512-0102

CHEVROLET SILVERADO AND GMC SIERRA 1500
2014-2018 2019 LD MODELS (ONLY)

ENGINE: 5.3L
FILTER CF-9400

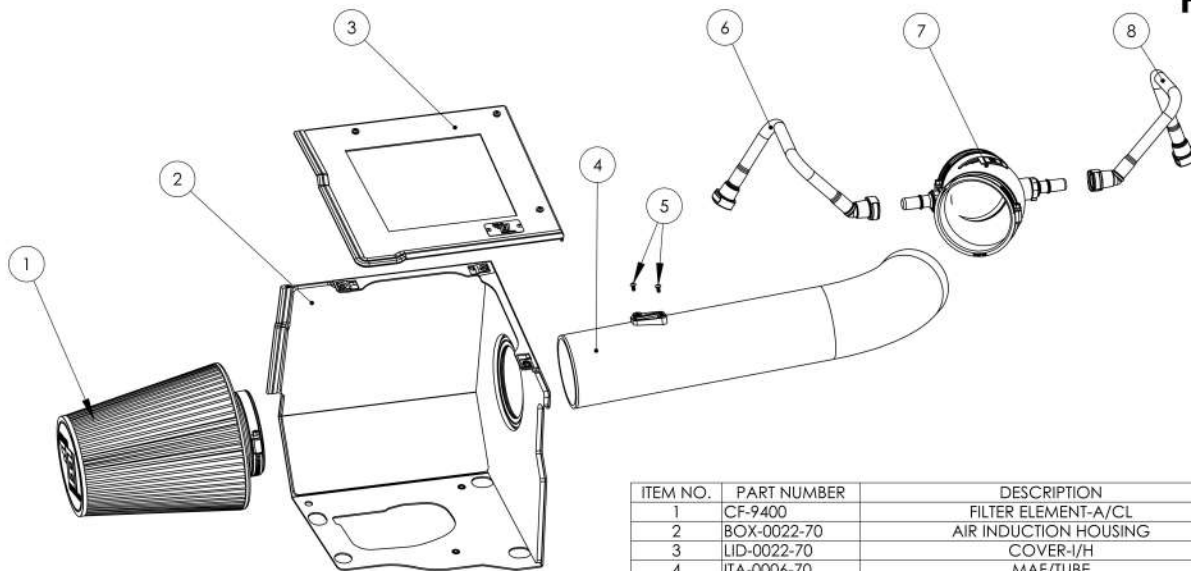

TOOLS NEEDED:

- Ratchet
- Extension
- 10mm socket
- 13mm socket
- 3mm allen wrench
- 2.5mm allen wrench
- 5/16 nut driver
- T10 torx

ITEM NO.	PART NUMBER	DESCRIPTION	QTY.
1	CF-9400	FILTER ELEMENT-A/CL	1
2	BOX-0022-70	AIR INDUCTION HOUSING	1
3	LID-0022-70	COVER-I/H	1
4	ITA-0006-70	MAF/TUBE	1
5	FTN-0001-BCM	M4-0.7 x 8mm S.S. BUTTON HEAD CAP SCREW	2
6	PCV-0002	PCV/TUBE	1
7	ITR-0004-ASM	INLET/DUCT	1
8	PCV-0003	PCV/TUBE	1

If you need any assistance, **PLEASE VISIT OUR WEBSITE WWW.COLDAIRINDUCTIONS.COM TO VIEW THE INSTALL VIDEO** or call 1-810-392-9999 to speak with a customer service representative.

NOTE: FAILURE TO FOLLOW INSTALLATION INSTRUCTIONS AND NOT USING THE PROVIDED HARDWARE MAY DAMAGE THE AIR INDUCTION SYSTEM, THROTTLE BODY AND ENGINE.

REMOVAL OF OEM SYSTEM



1. Turn off the ignition. Let the engine cool before installation.



2. Disconnect the negative battery cable with the 10mm socket and ratchet.



3. Remove diagonal brace using 13mm socket and ratchet.



4. Loosen screws from CLEAN/AIR DUCT RESONATOR with 5/16 nut driver.



5. Unclip PCV fitting from valve cover.



6. Remove CLEAN/AIR DUCT RESONATOR from vehicle.



7. Gently disconnect the MAF sensor from its housing and set out of the way.



8. Remove MAF wire harness from the AIR INDUCTION HOUSING.



9. Remove OEM AIR INDUCTION HOUSING.



10. Make sure both grommets are intact in the grommet holes on the vehicle.

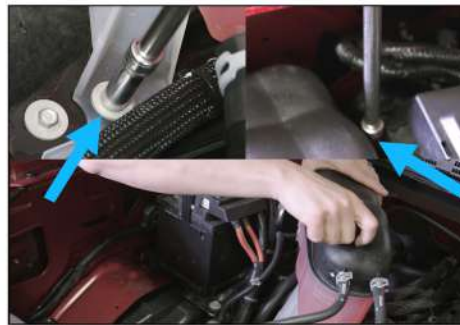

11. Using a 10 mm ratchet and socket unscrew one nut and one bolt, remove OEM overflow coolant bottle and place near valve cover out of way.



12. Place the factory AIR INDUCTION HOUSING on work bench. Remove the MAF SENSOR by removing the two screws holding it in place on the AIR INDUCTION HOUSING with the T10 torx driver. Take care not to damage the sensor as you will reinstall in the performance MAF/TUBE.

INSTALLATION OF NEW CAI SYSTEM



13. Remove rubber mounting pad.



14. Remove BUTTON HEAD CAP SCREWS on the performance MAF/TUBE with 2.5mm allen wrench.
15. **IMPORTANT** Leave plastic insert inside of the tube and align holes where the MAF Sensor will be placed. **NOTE:** Do NOT install the filter prior to the MAF SENSOR. That would cause the insert to be misaligned with the MAF/TUBE.



16. Install MAF sensor into performance MAF/TUBE, reinstall two BUTTON HEAD CAP SCREWS. Torque to 2.5 ft lbs.



17. Remove COVER from the performance AIR INDUCTION HOUSING with a 3mm allen wrench.



18. Remove the protective film over glass.



19. Install the factory rubber mounting pad onto the performance AIR INDUCTION HOUSING.



20. Install performance AIR INDUCTION HOUSING into vehicle making sure the rubber mounting grommets slide into the grommets on vehicle.



21. Reinstall the coolant reservoir.



22. Install INLET/DUCT onto throttle body.

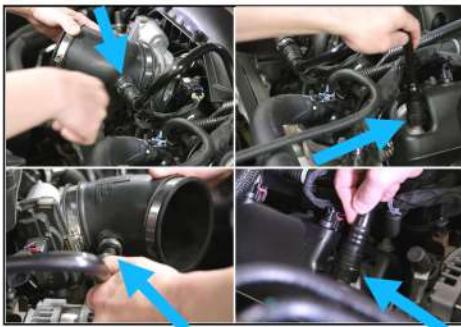

23. Connect both PCV/TUBES onto INLET/DUCT and valve cover.



24. Insert tube into INLET/DUCT and leave all connections loose.



25. Insert FILTER ELEMENT onto MAF/TUBE. Tighten the clamp on FILTER ELEMENT with 5/16 nut driver.

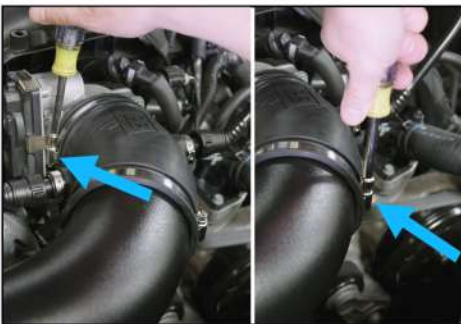

26. Align MAF/TUBE and coupler then tighten both hose clamps using 5/16 nut driver.



27. Attach the COVER to performance AIR INDUCTION HOUSING, using a 3mm allen wrench, gently push and turn the fasteners a quarter turn (only).



28. Reconnect MAF sensor



29. Reinstall the diagonal brace using the 13 mm socket and ratchet.



30. Reconnect battery terminal with 10mm socket and ratchet.



31. Slowly lower your hood and check for clearance.
32. Time for a test drive.

*****IMPORTANT*****

Warranty Registration Instructions

***This product comes with a Limited Lifetime Warranty against material defects and product craftsmanship. The intake kit must be registered online for your warranty to be activated. To register your product go to:

www.coldairinductions.com/contact-us/register



NOTE: NOT LEGAL FOR SALE OR USE IN STATE OF CALIFORNIA



Cold Air Inductions Inc. 717 Burnell Rd. Memphis, MI 48041
Phone: 810-392-9999 Monday-Friday 8:00 am to 4:30 pm EST
Web: coldairinductions.com Email: support@coldairinductions.com
